

CUSTOMER PART No.

CUSTOMER

**CAN ART STD.**

DIE No.

**EH05566**

DESCRIPTION

2 1/2" x 1 1/4" x 0.125" THK. RECT. TUBE

PROPOSAL No.

H-6612

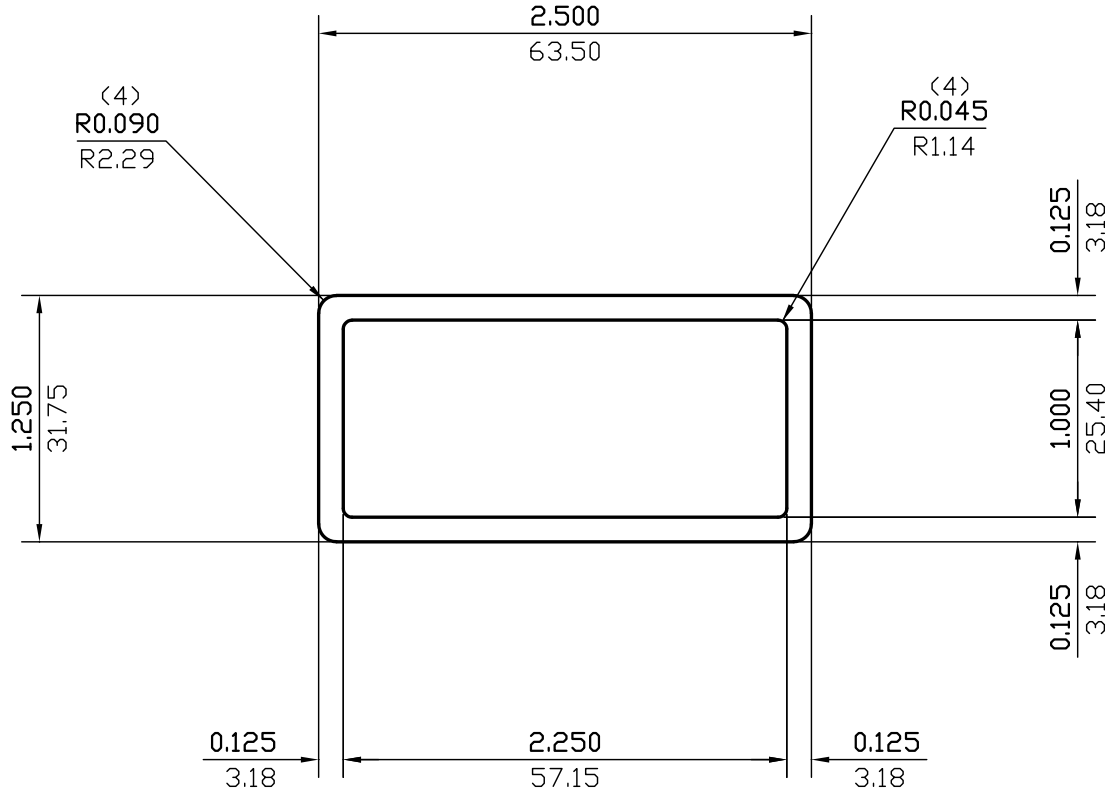

NOTE: BREAK ALL CORNERS WITH 0.015" (.38 MM) RADIUS UNLESS OTHERWISE NOTED. STANDARD TOLERANCES TO APPLY UNLESS OTHERWISE SPECIFIED.

WALL THICKNESS 0.125 (3.18) EXCEPT AS SHOWN

DATE	REV	DESCRIPTION	BY
03/15/23	3	REMOVED ALLOY	JASON
08/10/99	2	REDRAWN	P.M.
EST.AREA	0.870	IN. <sup>2</sup>	EST.AREA 561
			MM. <sup>2</sup>
EST.WT.	1.044	LBS/FT.	EST.WT. 1.553
			KG/M.
EST.PER.	13.768	IN.	EST.PER. 349.7
			MM.
OUT PER.	7.345	IN.	OUT PER. 186.6
			MM.
C.C.D.	2.733	IN.	C.C.D. 69
			MM.
FACTOR 13	FINISH M/F	ALLOY & TEMP.	
CKD BY	SCALE 1:1	DWN BY C.P.	DATE 06/24/97

**CAN ART**

ALUMINUM EXTRUSION INC.

85 PARKSHORE DRIVE  
BRAMPTON, ONT L6T 5M1  
TEL. NO. (905) 791-1464  
FAX NO. (905) 791-9151  
E-MAIL: canart@canart.com

THIS DRAWING IS NOT NECESSARILY A COPY OF YOUR ORIGINAL. PLEASE APPROVE DIMENSIONS AND TOLERANCES INDICATED. CAN ART ASSUMES NO RESPONSIBILITY EITHER TECHNICAL OR LEGAL FOR HAVING THIS SHAPE MADE. THE CUSTOMER AGREES TO FULLY PROTECT CAN ART ALUMINUM FROM CLAIMS OF OTHERS RESULTING FROM THIS SHAPE.

SIGNED: \_\_\_\_\_ DATE: \_\_\_\_\_